

Align-Pilates®



C8-Pro Reformer Assembly Instructions & User Manual

Note: To check for the latest version of this manual please visit:
<https://align-pilates.com/pilates-equipment-resources/assembly-user-guides/>

For Patents & Patents Pending see www.Align-Pilates.com/Patents-&-IP

Introduction

Thank you for buying a C8-Pro RC reformer, the latest evolution of the popular C Series Reformer. The C8-Pro RC is the 8 wheel version of the C2 Pro-RC, featuring a number of enhancements that make this the premium C series reformer. This manual will show you how to build each variant of the C8-Pro RC.

Please ensure you read it fully before unpacking and assembling the equipment.

Specification & Adjustability

- Class leading travel of 106.5cm
- Rapid Change (RC) Spring bar that allows single handed adjustment of the spring bar with springs in place, without the need for a separate carriage stopper
- Resistance: 5 nickel plated quality music wire springs 3 different strengths (2 light, 2 medium and 1 strong)
- Large comfortable carriage 92cm (73cm from shoulder rest) x 58cm. Suitable for users: 145cm - 193cm
- Lockable Foot bar with 4 positions including flat
- Removable rope risers with 7 height positions and 7 rope length adjustments (not all heights usable without optional leg extensions)
- Anodized aluminium runners with 8 PU wheel system for smooth, quiet and low maintenance ride
- Align-Pilates 'silent' accessories, new patented Silent pulleys, metal free silent ropes with silent double loop handles and a silent foot strap for a quiet user experience
- 3 position head rest
- Off centre shoulder rests provide a choice of widths for your shoulders
- Space saving – The C8-Pro RC is wheeled for ease of movement and storage and can be stacked or "free stand" when selected with the extension leg option or, free standing legs option
- Height adjustable feet for perfect alignment
- Includes holder for a Gondola pole or maple pole (both sold separately)
- ISO20957-1 Class S Item. Max User Weight: 150kg.

Dimensions:

Reformer only: 235 (L) x 66 (W) x 24cm (H). Reformer with Leg Extensions: 235 x 66 x 42cm. Weight: 59kg (GW)

Assembly

1. Unpacking the C8-Pro RC reformer

Warning: the main box for the C8-Pro reformer weighs around 40kg so at least two people are required to unpack the equipment. You should have 2 outer boxes as shown below.

At all times you are responsible for your own safety and those around you. Please unpack the equipment in a clear, clean & dry environment on a level floor surface. Remove all strapping using a safety knife and remove the carton lid. The reformer frame will be wrapped in a plastic wrapper and protected by polystyrene blocks, carefully cut the plastic wrapper open and inside the carton you will find 2 inner boxes as shown below, place these to one side. Then with a person on each end carefully lift the reformer frame out of the box and place on a level surface, free of obstructions.

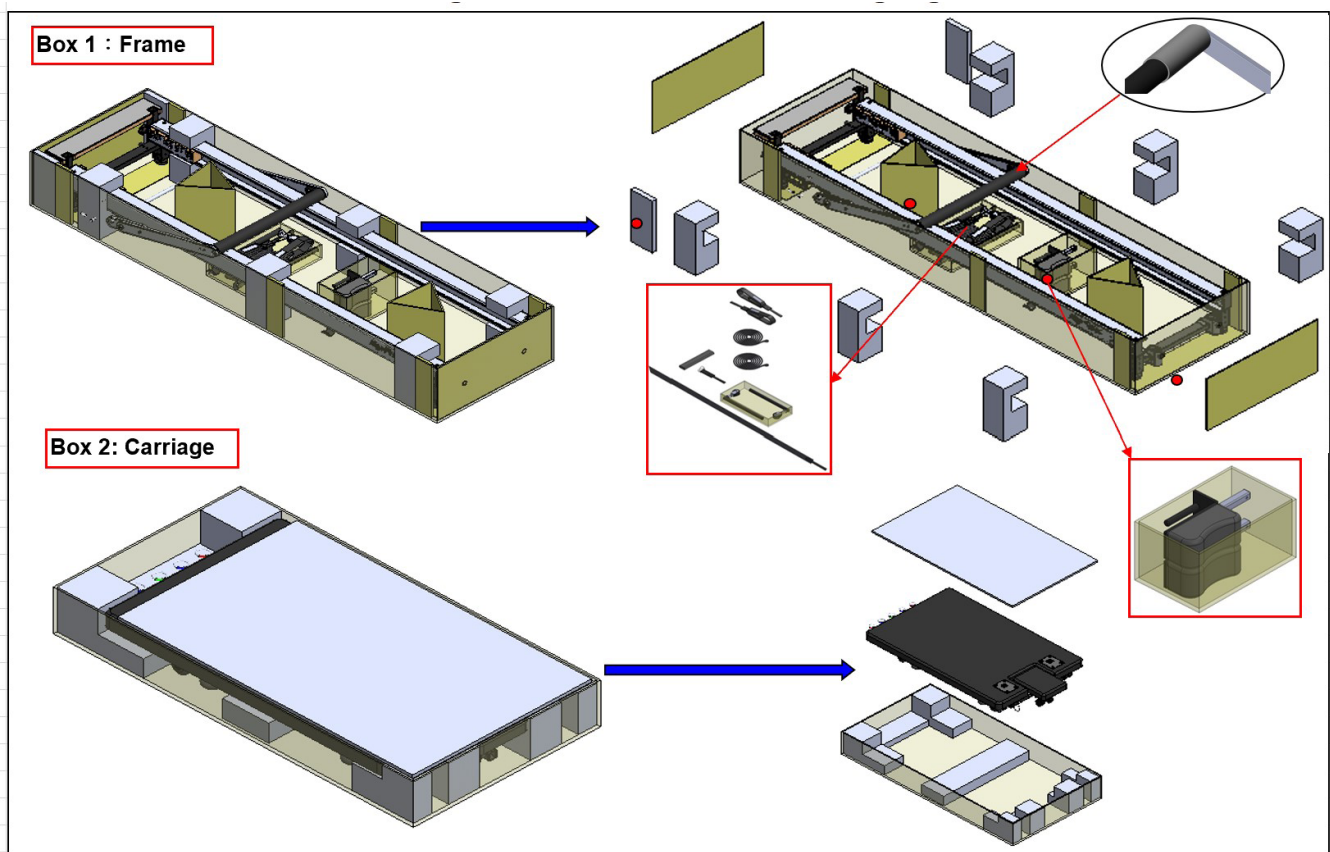

2. Assembling the foot bar

- a) Carefully cut off the cable ties holding the foot bar in the folded position on top of the frame.
- b) Cut off the cable ties holding the chrome Gear bar (#26 - see exploded diagram on page 11) and position it in the 3rd slot away from the end of the reformer.
- c) Now insert the M8 x 15mm dome headed bolt from the inside and hand tighten. See Fig. 2. Repeat on the other side.
- d) Now bolt the Foot bar Selector bar to the chrome Gear bar (#26) from the outside using the M8 20mm bolt (#103) . Repeat on the other side, but do not fully tighten. See Fig. 1.
- e) When all bolts are in go round and fully tighten all four bolts with the provided allen key



Fig.1

Note: at this point if you have only ordered the C8-Pro RC, without the extension legs or freestanding leg attachments please jump to section 5.

3. Attaching the Leg Extensions* (optional extra)

If you bought the optional leg height extensions now is a good time to attach them. We recommend you get a pair of stable trestles to put the reformer on to enable easy fitting of the legs. Ensuring the trestles have something soft on them to avoid scratching the frame, lift the reformer and place it on to the trestles, so that one trestle is underneath the point where the foot bar attaches to the runner and the other is near the rope riser end.



Fig.2

Remove the wheel bracket at the foot end of the reformer, placing all nuts, bolts and washers to one side. Store the parts in the order you removed them and then reinstall the wheels on to the higher legs. Remove all four of the black adjustable screw in feet by unscrewing them completely out and then screw these completely in to the C8-Pro leg extensions.

Using the allen bolts and a 6mm Allen key, screw in the 5 bolts per leg and hand tighten. Be careful not to cross thread the bolts. Once all the bolts are in, tighten fully with the Allen key. After removing your trestles or other elevation device, put your reformer down where you intend to use it. Then use a spirit level to check the reformer is level and stable. Adjust the level of the reformer by turning the rubber feet in or out. The parts list and exploded diagram is shown in Fig. 3 for your reference.

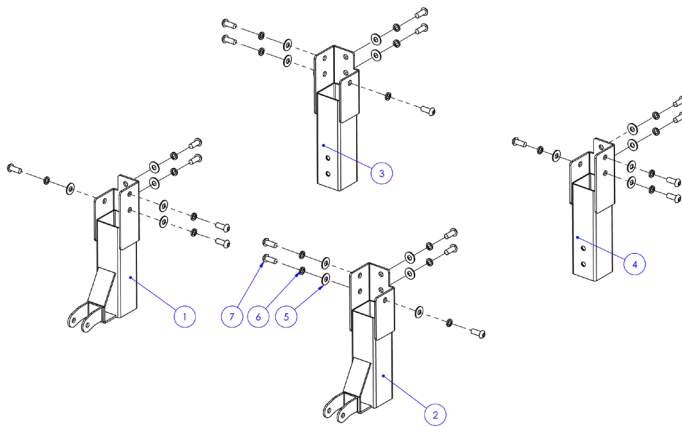

Ref	Name	Specification	Qty
1	Right* leg foot bar end		1
2	Left* leg foot bar end		1
3	Left* leg rope riser end		1
4	Right* leg rope riser end		1
5	Flat washer	8.5*20*T1.5	20
6	Spring washer	8.3*12.7*T2.0	20
7	Nickel plated Allen Bolt	M8*20	20

* Leg positions as it standing at foot bar end looking toward rope risers

Fig.3

4. Free Standing Legs* (optional extra)

The C8-Pro RC model has the ability to free stand with the addition a pair of freestanding legs (optional extra), shown in Fig.4, which bolt on to the frame. To install the legs simply remove the 4 bolts (#143), position the leg bracket so that the leg can fold inwards, then thread the bolts back through the frame and leg and hand tighten. When all 4 bolts are in tighten fully with a 6mm allen key. To use the legs, remove the safety pin from its storage location, then stand the reformer, once vertical open both the legs 90 degrees with your foot and let the reformer free stand. Now reinsert the safety pin to lock the legs open. To lower remove the safety pin, then whilst supporting the reformer, take the pressure off the legs and fold them in with your foot then lower the reformer carefully down. Note: When standing the reformer always make sure the spring bar is in the position closest to the standing platform before lifting.



Fig.4

*Both the leg extensions & freestanding legs packages include a new Safety sticker. Please stick this on to the reformer frame between the rope risers, such that is readable when standing ready to lift the reformer.

5. Insert the Reformer Carriage & checking the side wheel adjustment

With the reformer back on the floor, firstly remove the 2 rubber carriage stoppers from the end of the runners (Fig. 8). Carefully remove the carriage bed from its packaging. Before inserting the carriage familiarise yourself with the side wheel set up and adjustment system (Fig. 7). Now with one person holding each side of the carriage bed, gently slide the carriage in to the runners (Fig. 5) with the springs pointing towards the standing platform.

After attaching at least one spring, roll the carriage back and forward checking that the carriage runs freely for the whole length of the runner. There should be no squeaking or interference from the side wheels, if there is the side wheels need to be moved inwards. Conversely there should not be excessive side to side movement of the carriage in the runners or the wheels need to be moved out.

If you have leg extensions adjustment of the side wheels can be done from under the machine, if you do not it is advised to remove the carriage to adjust the wheels.

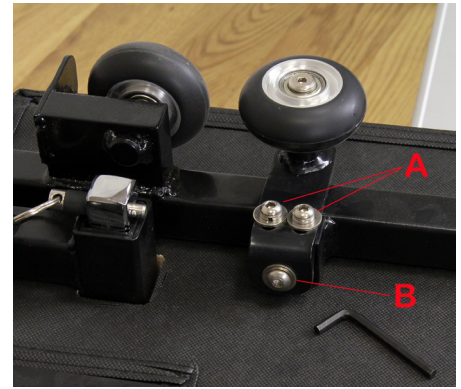

Fig. 7

To move the side wheels in (ie because they are causing the carriage to jam or, causing squeaking noises) unscrew bolt B a few turns (Fig. 7) then loosen the two A bolts and push the wheel bracket in until it hits the stop screw B, then retighten bolts A - now try the carriage again. If there is too much side to side movement of the carriage then the side wheels need to be moved out. To do this loosen bolts A, then tighten bolt B by a few turns, which will push the wheel out, then retighten bolts A and try the carriage again. We recommend small adjustments each time and after a few trials you should get the carriage to run perfectly, with no interference from the side wheels & little side to side movement possible.

6. Runner stoppers

Having installed the carriage now screw the stoppers back in hand tight. The stoppers prevent the carriage from hitting the rope risers and are designed to allow for quick removal of the bed for cleaning & maintenance, (Fig.7). Simply unscrew to get access and ensure you re-screw them back in before use.

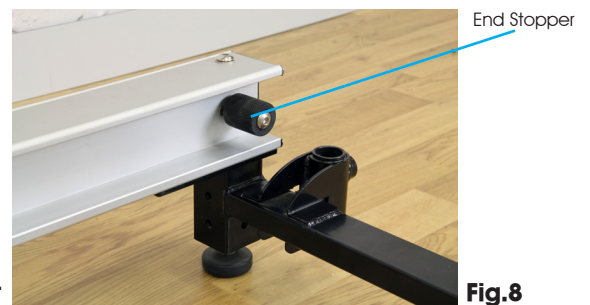

Fig.8

7. Offset Shoulder rests

Insert the shoulder rests into each of the shoulder rest receiving holes on the carriage bed (Fig. 9). They can be locked in place by placing the locking pin through the hole at the bottom of the chromed bar (Fig. 10). The locking pins are attached on a string to the underside of the carriage as shown in Fig 10.

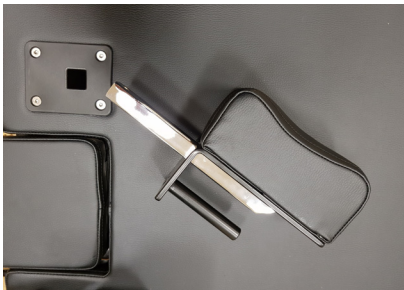

Fig.9



Fig.10

Please note the new design of shoulder rests have one side offset, this means you have a choice of a narrower or, wider position for the shoulder rests, according to how you insert them. See Fig. 11 & 12.



Fig.11



Fig.12

8. Attaching the rope risers:

Part screw in the 2 adjustment knobs and insert the riser (Fig.13 & 14), then pull back on the knob and slide the riser to the desired height. When happy with the height let go of the knob and twist to tighten and secure the riser in place (Fig.15).



Fig.13



Fig.14



Fig.15

9. Attaching & setting up the Silent ropes:

First attach the silent handles by threading the nylon loop of the handle through the rope eyelet and then thread the loop handle through the nylon eyelet to secure the handle to the rope as per Figs. 16, 17 & 18. Pull tight to check it is secure. Now pass the end of each rope through the pulleys on the end of the rope risers.



Fig.16



Fig.17



Fig.18

Next pull the rope adjusting T bar all the way out as in (Fig 19). The T bar position is changed by loosening the knob and then pulling back to disengage the locking pin, so that the bar can be slid back or forward. Now put the spring bar in position 1 (Fig. 20) and place the nylon loop of the handle over the rope holder poles as in Fig 19. **For the next part we recommend standing the reformer up (see 18a), with the assistance of another person, so that they can hold the machine, whilst you make the required adjustments.** With the reformer upright thread each rope through the rope holes on the T bar and pull the rope tight and then knot each rope so that the knot is flush against the tube.



Fig.19



Fig. 20

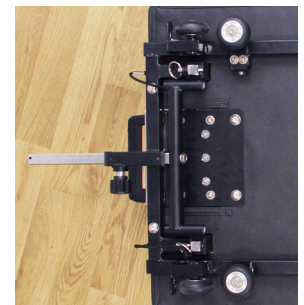

Fig.21

Repeat for the second rope and then check that the ropes are adjusted to exactly the same length, if they are not; adjust one of the knots, the ropes should be taught with the nylon loop of the handle on the rope holder poles, whilst making these adjustments. When both ropes are the same length and the knots pulled tight, tie an extra knot in the tail of the rope for safety. The ropes tails can be coiled around the T bar to get them out the way.

To adjust the ropes when using the reformer, both ropes are simultaneously adjusted by loosening the adjustment knob underneath the head rest, pulling back on the knob and sliding the T bar in our out. Sliding the T bar in Shortens the ropes & pulling it out (Fig. 21) lengthens the ropes. Therefore as you move the spring bar away from the standing platform you should move the T bar in under the carriage.

In summary when the spring bar is in position 1 the chrome part of the T bar should be all the way out (completely visible) and for position 4 only the end of the chrome T bar should be visible.

10. Foot Strap installation:

- 1) Separate the strap in to 2 parts. Taking one half of the strap, thread the nylon loop through the eyelet on the reformer frame under the jump board (Fig. 22)
- 2) Now pass the foot strap through the loop and pull tight (Fig. 23)
- 3) Repeat this process for the other half of the strap (Fig. 21) and finally re-thread the strap through the D-ring (Fig. 24) and the strap is ready to use (Fig.25).



Fig.22



Fig.23



Fig.24



Fig.25

11. How to adjust the foot strap:

To tighten - simply pull on the end of the strap.

To loosen - first loosen the strap at the D-ring and then the strap can be pulled out to be lengthened.

The foot strap is best with it passing between the legs (above the cross support and below the jump board).

12. Adjusting the rapid change (RC) spring bar

The new patent pending Rapid Change (RC) spring bar (Fig. 26), dramatically changes the speed and ease of moving your spring bar! Simply lift it up & move it to the desired new location. Adjusting the RC spring bar is up to 12 times faster than moving a traditional spring bar, which required removal of springs, moving the stopper, moving the spring bar & reattaching the springs – enjoy!



Please note there is no longer a removable carriage stopper as there are integrated carriage stoppers on the side arms of the Spring bar (Fig.27)

Important - The RC spring bar must always be moved with at least one spring attached.

Fig.27



Fig.26

13. Working with springs

Spring strength is indicated by the coloured anodized nuts on the RC spring bar. Align-Pilates springs are made from nickel plated music wire for the best possible performance and for smooth progressive resistance. Green is strong (100%) , red is medium (75%) and blue is light (50%) - use in a combination to suit the desired exercise. To get maximum life out of your springs try to vary which springs you use as much as possible. For those seeking a lighter spring we offer an after market extra light yellow spring (25%) which requires a supported spring cover.

To change the springs position or replace the springs, go under the reformer, unclip the shock cord and unthread it from the spring eyelets, then uncoil the spring eyelet from the pig tail bolt and release the velcro on the spring covers so the spring can be removed. Switch the cover to the new spring and reverse this process. Springs must be replaced every 2 years or 3,000 hours whichever is sooner, however always replace springs immediately if there is any sign of deformation or damage and cease using immediately.

14. Adjusting & Locking the Foot Bar

The C8-Pro RC has a lockable foot bar that uses a locking pin, which is located on the side of the reformer (see Fig. 28). There is also a place to store the pin when not in use See Fig. 29 Note: The pin does not completely prevent movement in a backward direction but it stops a user from falling back when pulling on the foot bar in a direction away from the standing platform. To raise the foot bar, first ensure it is unlocked then pull the padded bar towards you stopping at the desired height. To lower the foot bar it helps if you hold the foot bar selector bar as well as the padded bar to lower it to the desired height. In either case once the desired position is achieved you can lock the bar in place with the locking pin. Note the bar does not lock when it is all the way down. Fig 28 shows the bar locked and Fig 29 shows the locking pin in the storage position, which keeps the pin out of the way when not being used to lock the foot bar.



Fig.28



Fig.29

15. Maple pole holder

A pair of hooks have been added to the underside of one of the runners for the convenient storage of a Gondola pole or, shorter maple pole (Fig. 30). Remember; if your reformer is fitted with leg extensions, you should always have a Gondola pole to provide 3 points of contact with the floor, when doing exercises standing on the reformer for safety reasons. Align-Pilates Gondola and Maple poles are available separately.



Fig.30

16. Getting Your Reformer Level

In order for your reformer to run smoothly and quietly it must be level. Starting with all the adjustable feet fully screwed in, adjust the feet out until the reformer is level, ideally checking it with a spirit level. **Tip:** Always lower a high foot before raising a low foot & be sure not to have more than 1cm of thread exposed. **Maintenance:** Periodically check all bolts that attach the legs to the reformer are tight.

17. Stacking your C8-Pro RC Reformer.

For Studio use the C8-Pro RC reformer has been designed to stack, for when the floor space is required for other purposes. To stack the C8-Pro RC with standard legs you must first remove the shoulder rests and the rope risers and place them along the centre of the carriage (do not put them on the edge of the carriage or they may be damaged by the reformer on top). Now put the foot bar in the down position. You can then stack the reformers on top of each other, the reformers must be stacked top to tail. If you have the C8-Pro RC with the leg extensions you can stack them without the need to remove the shoulder rests.

How to stand up & stack the C2 or C8 reformer scan the QR Code to watch the videos:



IMPORTANT: At least 2 people are needed to stack the reformers, particular if stacking more than 3 high. Each reformer weighs almost 60kg, so correct lifting technique must be used - if in doubt about how to lift safely please seek advice.

18. Storing the reformer vertically.

The C8-Pro RC reformer can be stood up for space saving storage, so long as it is fitted with leg extension or, with the freestanding legs (see point 4). **Warning: The reformer should only be stood on resilient, level floors in locations where it cannot be accessed by children or risk being knocked over by other activities.**

a) Standing the C8-Pro Reformer Vertically

To stand the reformer vertically, first attach all springs, put the foot bar in to the second lowest position. Put the spring bar in the position closest to the standing platform, then lifting from the rope riser end, wheel the reformer to the place where you wish to stand it - ideally close to a wall. If you have the free standing legs option, remove the locking pins before standing, once standing these can be opened out with your foot. Be sure to open the legs all the way out. Once standing please lock the legs in the open position, If you have leg extensions the reformer will stand on its own. Please do not stand the reformer on a rug or mat which can slip away.

b) Lowering the C8-Pro Reformer

To lower the reformer from the vertical storage position: firstly check there are no obstacles behind you to trip over when lowering. If you have the freestanding legs, first remove the locking pins, then holding the underside of the runners fold the legs in with your feet. Then walk backwards gradually walking your hands up the runners as you step backwards and lower the machine to waist height and manoeuvre in to desired position using the wheels.

Note: the C8-Pro RC reformer weighs around 55Kg and though standing or, lowering the reformer does not require lifting the full weight, if in any doubt about standing the machine up try to do this with the aid of another person for the first few times until you are confident that you can do this on your own. Always use correct lifting technique when first lifting or lowering the reformer.

ESSENTIAL SAFETY & MAINTENANCE INFORMATION (read before use)

Periodic Maintenance

Please check the apparatus before first use and after each of the first few uses to check that all the fittings are securely fastened. Thereafter, it is important to follow a regular maintenance schedule by someone familiar with the equipment and record your maintenance checks. Equally inspection should be made immediately if any part appears not be operating correctly or, something appears to be loose. Below follows a basic maintenance guide though our detailed maintenance guide and a sample maintenance log can be downloaded from <https://align-pilates.com/pilates-equipment-resources/assembly-user-guides/>

Some of the suggestions here require the removal of the carriage. This is simple, requires no tools and only takes a couple of minutes. The sequence is 1) Remove the rope risers 2) Slide out the T bar & place on the floor with the risers. 3) remove the 2 rubber carriage stoppers from the insides of the runner 4) carefully slide out the carriage

- **Springs** - Inspect for signs of wear - look for deformation, kinks, gaps and corrosion. Springs showing signs of damage must not be used and must be replaced immediately. Springs must be replaced every 2 years or after 3,000 hours, whichever is first, or immediately if showing signs of fatigue or deformation
- **Foot Bar** - check that all allen bolts securing the padded bar to the aluminium arms and to the steel engagement bar and through the frame are tight, but be careful not to over tighten.
- **Runners** - ensure the runners are regularly cleaned and kept free from dirt as this is the main cause for a noisy reformer. If excess dirt is spotted on the runners then the wheels may also need cleaning. We recommend cleaning the runners with a window cleaner eg. Windowlone.
- **Ropes and Handles** - check ropes for signs of wear, fraying or nicks and replace if damaged. Check stitching on handles and silent foot strap is intact and handles are not overly worn.
- **PVC Upholstery** - always ensure that belts, jewellery and shoes are removed when working on the equipment as buckles, rings, watches and bangles can all end up damaging the upholstery. For cleaning upholstery we recommend cleaning with [Gymwipes Advantage from vital-clean.de](#), which are available worldwide. For further information on cleaning recommendations see the link above.
- **Wheels** - Remove the carriage and check for smooth rotation, if the wheels are not turning smoothly or are scarred or damaged this will impede the smooth and quiet running of the equipment and the wheels need to be replaced. If squeaking occurs from the side wheels they may need adjusting as per point 5.
- **Shoulder Rests** - check the pads are securely bolted on to the metal frame - if loose retighten.
- **Spring hooks** - hand check that all eye hooks will not move. If loose remove, apply loctite and retighten. Check that the spring retention bungee is correctly attached underneath the carriage.
- **Nuts & Allen Bolts** - check all nuts and bolts are tight, including those on the rope pulley wheels and those securing the head rest and optional legs or freestanding leg attachments (if attached).

Basic Reformer & Exercise Safety

If you are not familiar with using a Pilates reformer we suggest you seek advice from a qualified Pilates professional in order to learn how to get the most out of your reformer and to cover the basic safety aspects of using this type of equipment. A number of companies also offer short safety induction courses.

- 1) Pilates is about smooth and controlled movement. When performing exercises try to prevent the carriage from slamming in to the carriage stops and the springs from recoiling in an uncontrolled manner as this can damage the springs and shorten their life.
- 2) Secure the carriage with at least one spring when your Reformer is not in use, Do not get on the carriage when there are no springs attached unless you deliberately want to do this.
- 3) When standing on the reformer always put your first foot on the standing platform and then the other on the carriage. When getting off the reformer from standing take your foot off the carriage first and then step down off the standing platform. If leg extensions are in use then a Gondola pole should always be used when standing on the reformer.
- 4) Use your reformer in a clear space with at least 1m of space all around the machine. This equipment is for indoor use only on a firm and flat surface
- 5) When using a reformer less is often more, remember when performing certain exercises less spring resistance makes the exercise more challenging.
- 6) Before starting any exercise program, consult a physician.
- 7) Before using the equipment, read and follow instructions in the safety manual and obtain thorough instruction from a Qualified Trainer.
- 8) Use equipment only for recognised Pilates repertoire.
- 9) Stop exercising if you experience chest pain, feel faint, have difficulty breathing or experience musculoskeletal discomfort.
- 10) Keep clothing, body and hair free from all moving parts.
- 11) Do not use if equipment appears worn, broken or damaged. Do not attempt to repair equipment yourself. Ensure equipment that is out of service cannot be used.
- 12) Do not allow children to use or be around equipment without adult supervision.
- 13) If standing the equipment for storage be sure it is kept in a safe place, on level ground and away from children or activities that could knock it over. If in doubt secure the equipment in an appropriate manner.
- 14) Do not exceed the maximum user weight for the equipment which is 150Kg.
- 15) The C8-Pro RC can be moved & stood up by a single person with relative ease, as the weight is similar to lifting a heavy suitcase. However, if you have back or similar issues you should avoid moving or standing the C8-Pro RC alone.

Congratulations! You are now ready to use your C8-Pro RC Reformer. Now would be a good time to make a note to replace your springs in 2 years or, within 3,000 hours of use, whichever is sooner. We hope that you enjoy using your new C8-Pro RC reformer!

Accessories for your C8-Pro RC Reformer

The C8-Pro RC Reformer has a complete range of optional accessories including: Leg height extensions, Jump Board, Mattress Converter, Platform extender and Sitting Box. The reformer can also accept a Half Cadillac frame or a Full Cadillac frame (the full cadillac frame can only be used in conjunction with the C8-Pro Leg extensions) making the C8-Pro RC the most adaptable reformer in its class. Please note all the accessories above are the same for all our other C series reformers, including C1, C1R, C1-Pro, C2-Pro & C2-Pro RC.

For the complete range of Align-Pilates apparatus & a complete range of Pilates mat work accessories please visit www.Align-Pilates.com.



Jump Board & Leg Extensions



Mattress Converter with Platform Extender & Leg Extensions



Sitting Box (choice of two models)



Full Cadillac Frame with Mattress Converter & Platform Extender

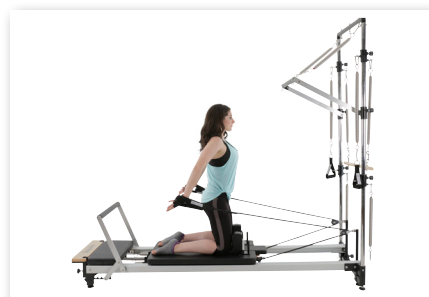

Half Cadillac Frame with Platform Extender

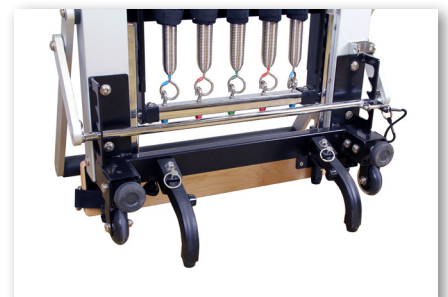

Freestanding Legs

C8-Pro RC Reformer Feature Map

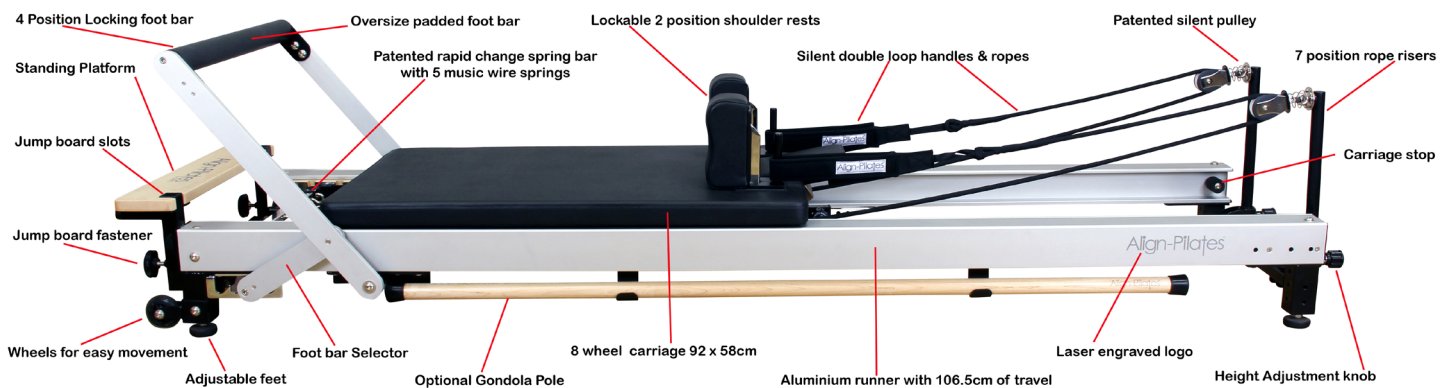

Align-Pilates[®] C8-Pro Frame

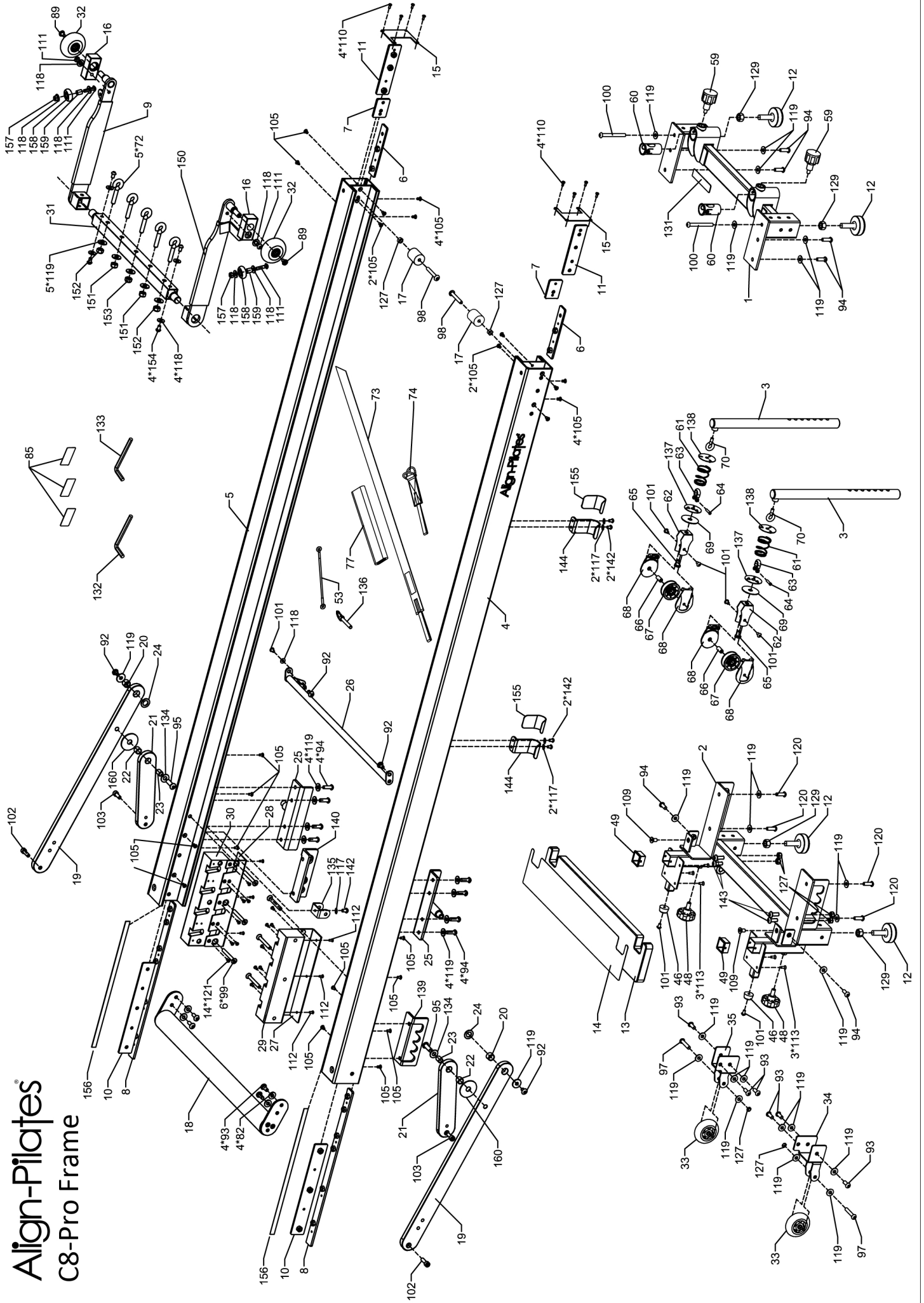

Warranty Information

ALIGN-PILATES™ LIMITED LIFETIME WARRANTY

Terms of Limited Lifetime Warranty

Align-Pilates offers the following limited lifetime warranty, for the periods as stated below from the date of purchase, to the original owner of their products, upon presentation of an original invoice in their name. The warranty is a Light Commercial Warranty allowing for a maximum usage of 27.5 hours per week.

Align-Pilates will repair or replace any mechanical part that malfunctions due to defects in materials and/or workmanship during the warranty period. The warranty excludes normal wear and tear, damage due to negligence or misuse, abuse, modification or unauthorized repair; scratches to the finish, and tears or indents in the upholstery. Align-Pilates will, at its discretion, repair or replace any parts deemed defective during the warranty period. If we opt to repair or replace your apparatus, this may require that your product is returned for inspection at our premises prior to sending out replacement apparatus. Parts repaired or replaced under the terms of this warranty will be warranted for the remainder of the original warranty period only. This warranty does not cover shipping charges, customs clearance fees (where applicable) or any costs incurred in installing repaired or replacement parts shipped under the provisions of this warranty.

This warranty will be null & void if springs are not changed as specified or, if all safety, maintenance and usage instructions as specified in the manuals are not observed or, if the equipment is used for any other purpose other than for recognized Pilates repertoire or, if the equipment has been subjected to accident, abuse, improper service, or modification not authorised by the Align-Pilates.

Duration of Limited Warranty

1) Metal & Aluminum Frames & welded components.

10 year warranty

2) Wooden Frames, Gear bar and foot bar mechanisms

5 year warranty. Wooden frames must not be positioned next to convection radiators or air conditioning units.

3) Other non-wear and tear components

2 year warranty

4) Ropes, Straps, Spring Clips, Handles, Fuzzies, Wheels, Foot straps, Rotational disks & powder coating

1 year warranty

5) Springs

2 year / 3,000 hours warranty is given on all springs, excepting that a decrease of 5% of the spring power per 1,500 hours usage is acceptable according to internationally standards. Align-Pilates Springs should be replaced after a maximum of 3,000 hours use or 2 years, whichever is earlier. In the event of any signs of damage or wear springs should be replaced immediately regardless of age or usage.

6) Upholstery

The upholstery fabric on Align-Pilates equipment will be replaced if it fails to give normal wear for 90 days from the date of delivery. Proof of damage may be required. This warranty does not cover cuts, scratches, burns, stains, soiling, or damages caused by unreasonable use such as wearing jewellery or inappropriate clothing whilst using the equipment. Align-Pilates reserves the right to substitute an equivalent fabric if an identical fabric is not available. Upholstery must be properly cared for – do not use chemical sprays or industrial soaps. Align-Pilates recommend using GymWipes (www.2xllcorp.com/contact-us/) to clean upholstery and wipe down equipment.

Warranty Return Procedure

The customer must call Align-Pilates or its authorized Distributor for authorization prior to returning the equipment. The customer is responsible for the cost of returning products to Align-Pilates (or their appointed Distributor) for warranty adjustment should this be deemed necessary. The customer is responsible for any damage or loss during shipment back to Align-Pilates (or their appointed Distributor). The customer is responsible for the cost of return freight to them in the event Align-Pilates decline to make a warranty adjustment. Align-Pilates do not accept responsibility for any items returned without a pre-approved authorization number, which must be clearly marked on the outside of the package.

Limitation of Liability

The above is our exclusive warranty and is in lieu of all other warranties, express or implied, including warranties of merchantability or fitness for any purpose. In no event shall Align-Pilates or their Distributors be liable for incidental, consequential or punitive damages.

CONTACT

This warranty is issued by Align-Pilates Equipment Ltd. Contact details: 430 Enterprise Way, Vale Park, Evesham, Worcs WR11 1 AD, UK. Telephone + 44 1386 425920. Email: customercare@align-pilates.com

For more information about Align-Pilates equipment please visit: www.align-pilates.com



Align-Pilates is a registered trade mark of Align-Pilates Equipment Ltd.